

# Integrating Combustion Technologies at Monroe Power Plant for NO<sub>x</sub> Control and Combustion Improvement



**David Tillman**  
**Plant Production Specialist – Combustion**  
**Monroe Power Plant**

**DTE Energy**





# Approach to Combustion Control and NO<sub>x</sub> Management

1. **Understand the Fuels Being Fired, and Optimize the Fuels**
  1. Optimize Fuels for Economics and Emissions
  2. Select a Fuel Blend to Maximize Fuel Potential
2. **Control Fuel Preparation**
  1. Blending
  2. Pulverizers
3. **Burner Technology**
  1. Recognize Unique Characteristics of Burners
  2. Modify Burners to Manage Situation
4. **Instrumentation: Install CO/LOI/FEGT Probes**
5. **Integrate with Other Technologies [Precipitator SIRS; Dense Pack on Turbine]**
6. **Training of Engineers, Shift Supervisors, Operations Personnel**



# Elements of the Combustion System and the Team

- **Key is Technology Integration**
  - Fuel Quality Measurement
  - Fuel Blending
  - Burners
  - Instrumentation
  - Precipitators; Turbine
  - Training of Shift Supervisors, Operators, and Engineers on New Technologies
- **Combustion as a Team Effort**
  - Fuel Handling Staff
  - Operations Personnel
  - Systems and Performance Engineers
  - Co-op Students from University of Toledo, Wayne State University, University of Michigan-Dearborn, Lawrence Technological University



# Technologies Implemented

- **On-line Coal Analyzer**
  - Basic analyzer
  - Digital Fuel Tracking System
- **Burner Modifications [Swirl-stabilized burners applied to very large burner systems]**
- **Instrumentation**
  - GE/MK Probes for Continuous Measurement of CO, Unburned Carbon Leaving Furnace, Furnace Exit Gas Temperature Mapping
- **Other Non-Combustion Technologies**



# The Keys to this Program

- **It is not one technology – not one silver bullet**
- **Many of the technologies are not new, but are new to this plant**
- **The key is integrating the technologies together through diligent application and training of technology users**
  - **Shift supervisors**
  - **Supervising operators**
  - **Engineers involved with fuel blending and combustion**
- **Treat NO<sub>x</sub> Reduction in the Overall Context of a Complete Combustion Program**



# Technology #1: On-Line Analyzer

- **For NO<sub>x</sub> Control – Maximize Volatility of Fuel**
  - **Maximum Volatility and Rate of Volatile Release Reduces NO<sub>x</sub> Formation**
  - **Lower Volatility or Delayed Volatile Release Increases NO<sub>x</sub> Formation**
- **Other Blending Objectives**
  - **Control Slagging**
  - **Control Opacity Emissions**
  - **Manage Fuel Variability**



# On-Line Analyzer Installation

- **Vendor: QC, Inc.**
- **Parameters Measured**
  - **Heat Content (Btu/lb)**
  - **Moisture (%)**
  - **Ash (loading – lb/10<sup>6</sup> Btu)**
  - **Volatile/Fixed Carbon Ratio (full proximate analysis)**
  - **Sulfur**
  - **Ash Chemistry**
  - **Base/Acid Ratio**

# On-Line Analyzer

- **This is not a “plug-and-play” instrument: requires constant attention**
- **Installation**
  - **Sampler system**
  - **Sample preparation (crusher)**
  - **Sampler**
  - **Conveyor returning sample to coal belt**
- **Samples coal on way to silos every 90 sec**
- **Coupled with Digital Fuel Tracking System and Silo Modeling to Determine Quality of Fuel Being Burned, and Quality of Fuel “in the Pipeline”**
- **Fuel Quality Screen for all Operators, Shift Supervisors, and Engineers**



# Coal Silo Contribution - DFTS

- **DFTS Relies on Silo Model of Flow of Coal and Coal Blends Through the Silo – Determines Fuel Quality at Burner and Before**
- **DFTS Model Includes Testing Coal Doped with Barium Carbonate**
- **Results Documented Variable Blend to Boilers and Documented Fuel Quality at Burner Front**

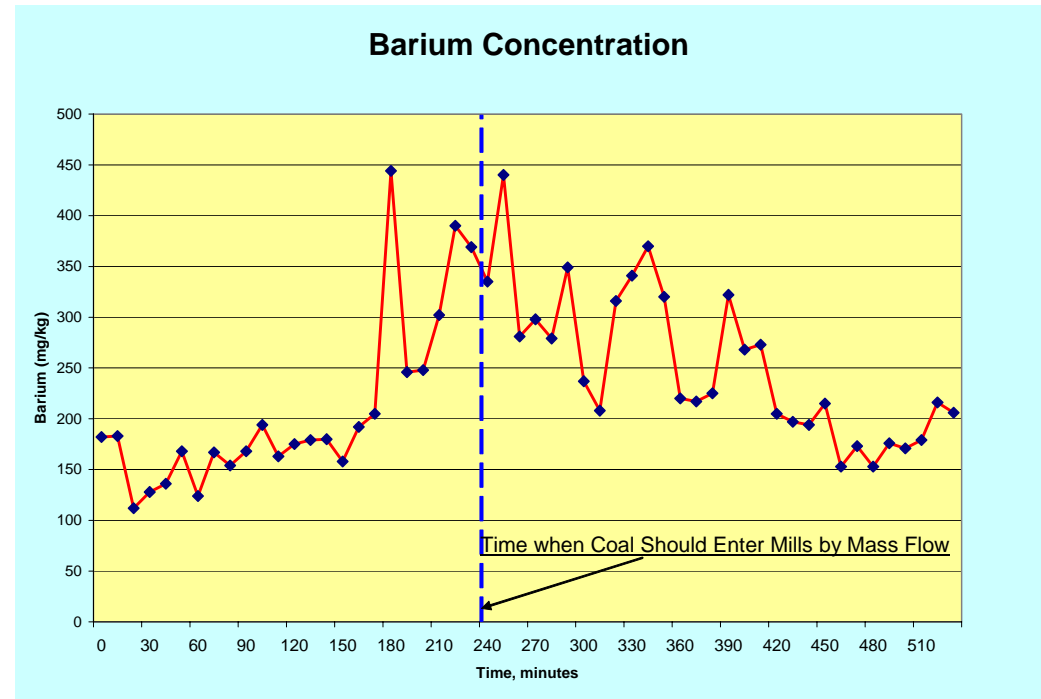



# On-line Analyzer Screens

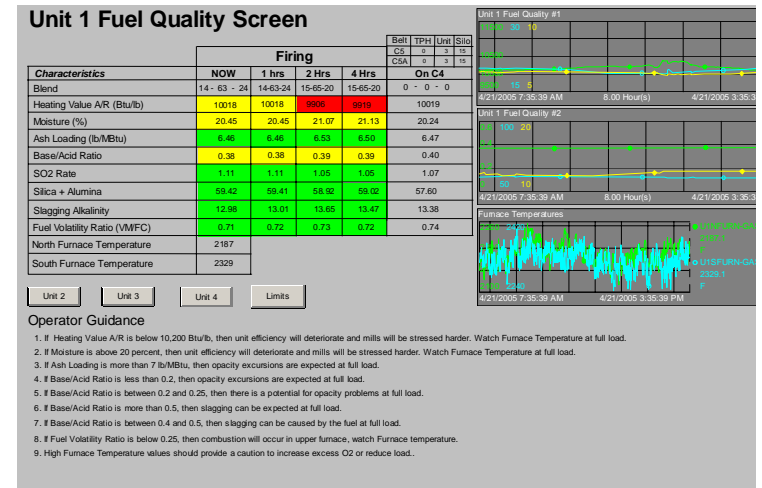

- **Used to Make Operating Decisions**
  - Selection of Coal Blend
  - Operating Parameters of Units
  - Optimizing Emissions Formation (NO<sub>x</sub>, Opacity)
- **Used as Early Warning for Potential Problems**
  - Capacity Loss
  - Slagging
  - Opacity
- **Analyzers on Rotary Car Dumper and Boat Unloader will Help Manage Coal Pile**



# Technology #2: The Burner Modifications Program

- **Existing Originally Used B&W Cell Burners**
- **Conversion in Mid 1990's**
  - One cell used as burner – one cell used as overfire air port
  - Two coal pipes from mill merged into one feeding burner
  - Burners used impellers, not swirl stabilization
  - Burners exhibited severe roping and long, laminar flames
- **Other Characteristics**
  - At full load each burner carrying ~35 MW ( $33 - 35 \times 10^6$  Btu/hr)
  - Each burner carrying load equal to 8' diameter cyclone
  - Very high load for pulverized coal burner (now common design for new boilers designed for such burners)



# Characteristics of Burners Before Modifications – Temperature

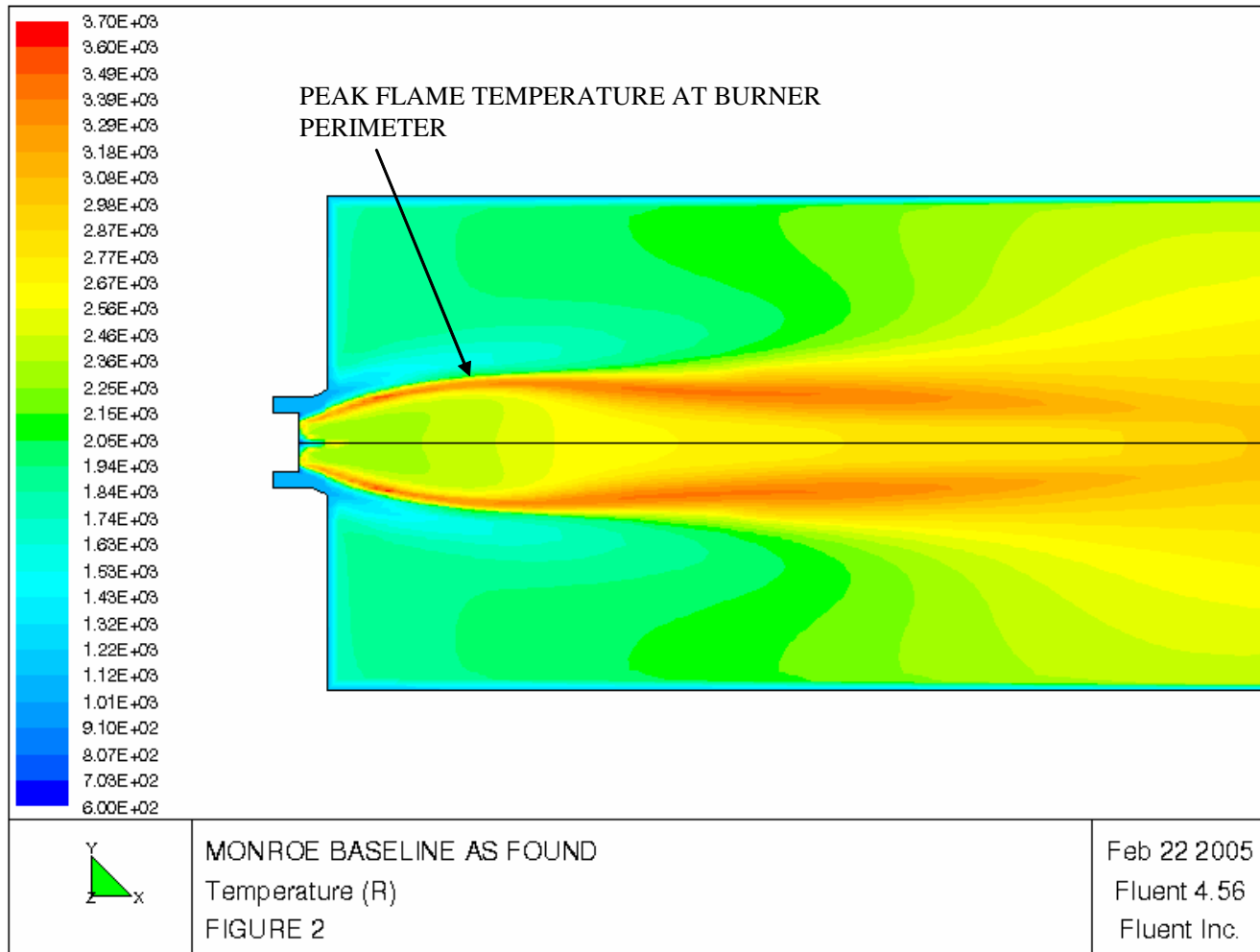



# Characteristics of Burners Before Modifications – CO Emissions

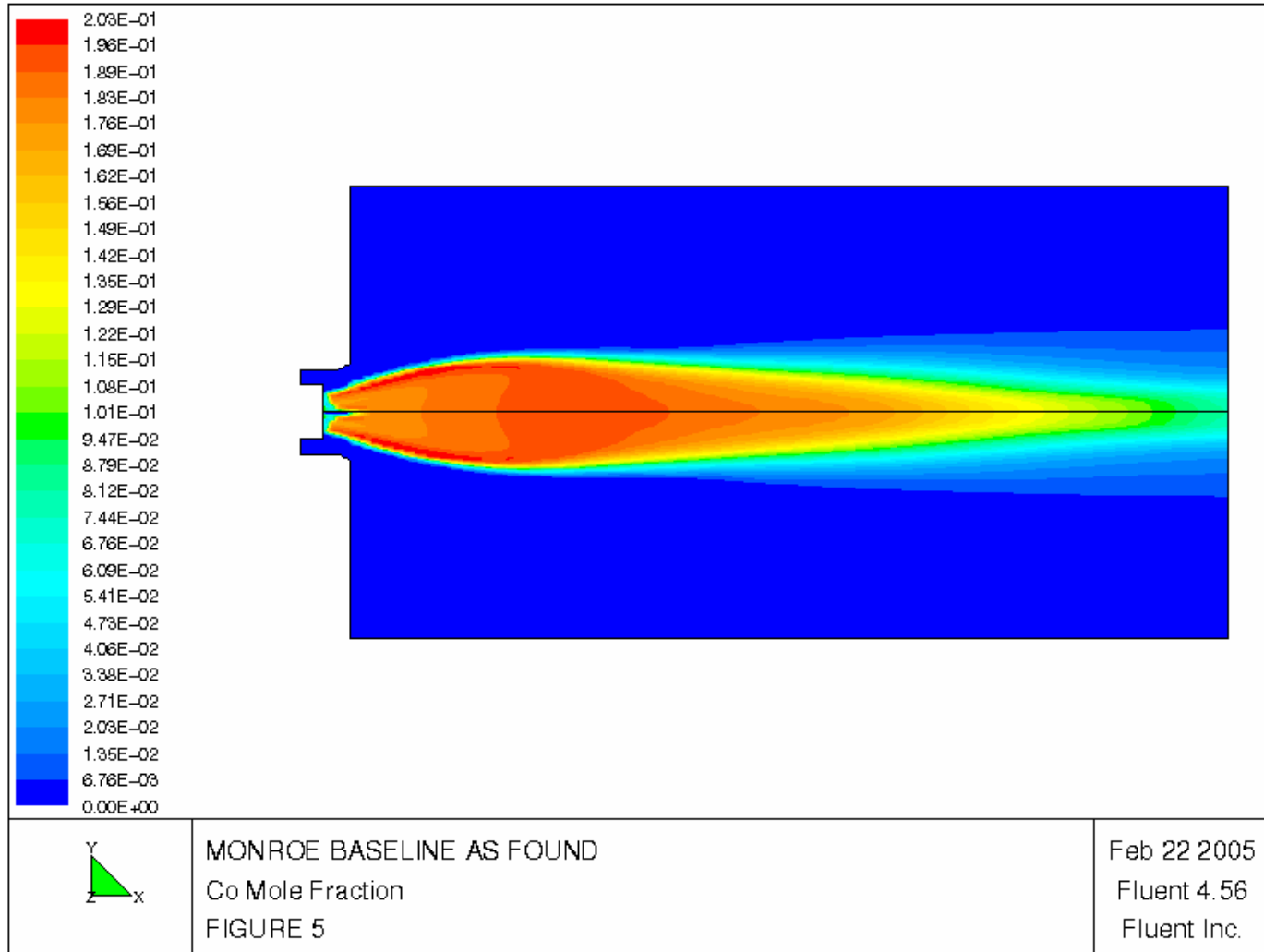



# NO<sub>x</sub> Formation in Boiler

- Fuel Nitrogen Driven
- Fuel Volatility Driven
- Temperature Driven
- Burner Modification Approach
  - Control Stoichiometry at Burner Front
  - Swirl Stabilization to Reduce Long Laminar Flames
  - Manage Combustion to Control Flame and Furnace Exit Gas Temperatures

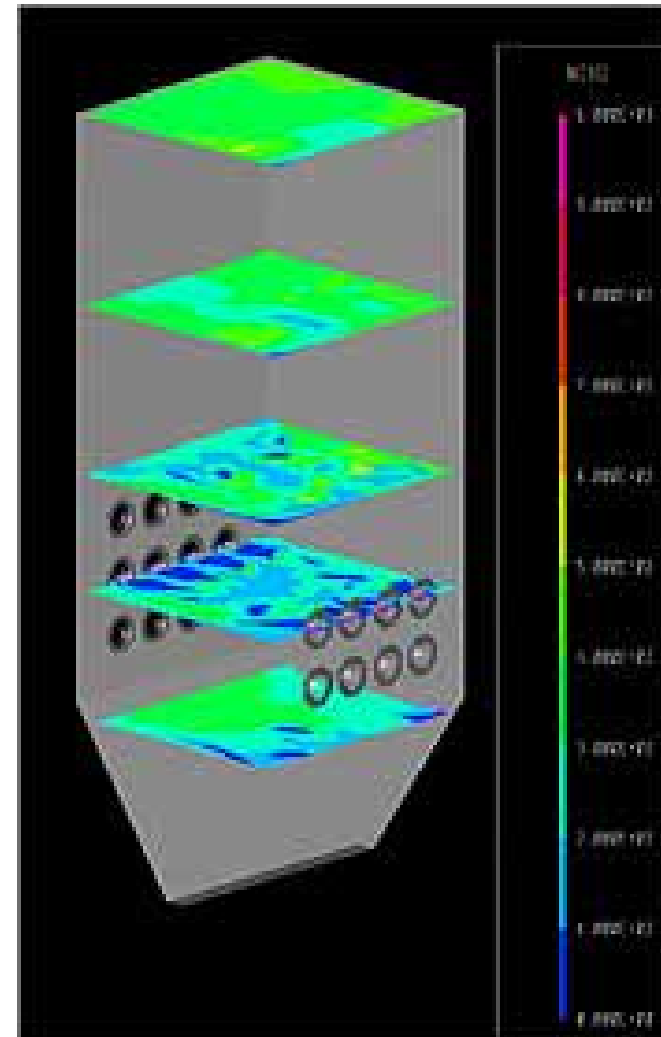

# Basic Burner Modifications

- **Vendor: ACT**
  - Experience with cyclones – high loads per burner
  - Experience with burner modifications
  - CFD and Cold Flow Physical Modeling
- **Installed Distribution Disc to Break Up Coal Rope**
- **Installed Swirl Stabilization System for Secondary Air**
  - Controlled Stoichiometry
  - Shortened Flame Somewhat – Eliminated Sandblasting Far Wall of Boiler – Created Recirculation Zone in Flame



# Burner Modifications – The Concept

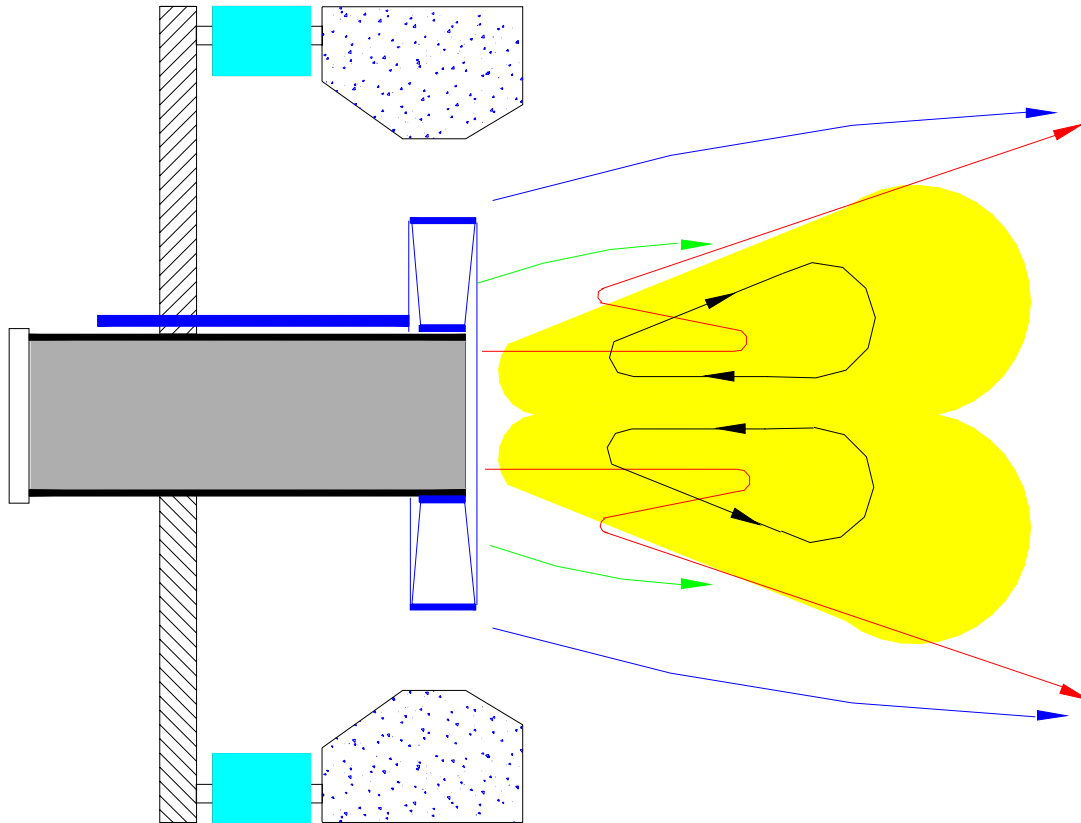



# The Modified Burner





# The Swirler Detail



# The Distribution Disc for Rope Breaking





# Results: The New Temperature Profile of the Flame

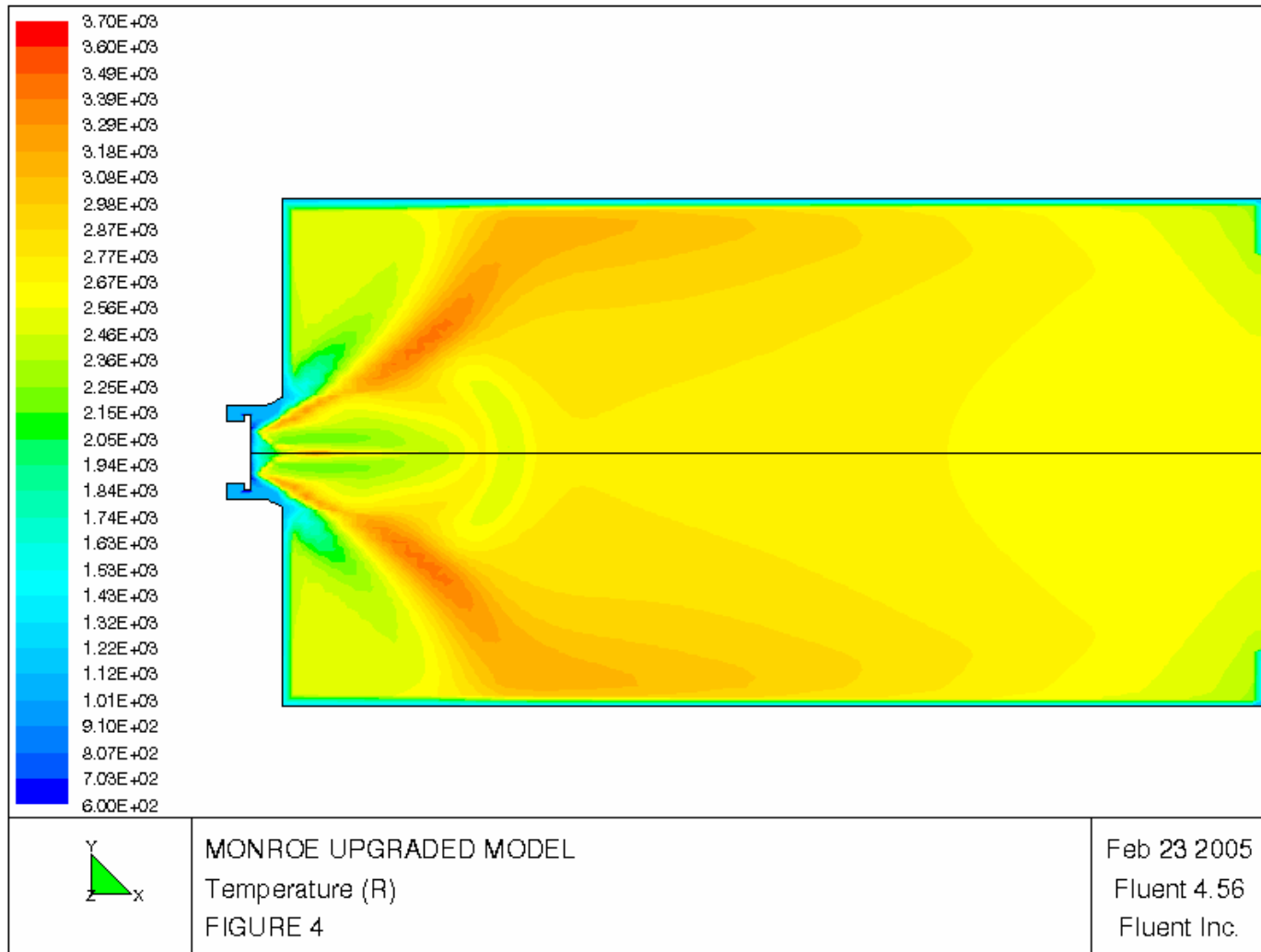

# Results – 2: Shorter Flame with More Complete Burnout

- **Shorter Flame – Not Sandblasting the Far Wall of the Boiler**
- **More Complete Burnout in the Flame Region – Less Combustion in the Upper Furnace and Lower FEGT**
- **Better Flame Pattern**

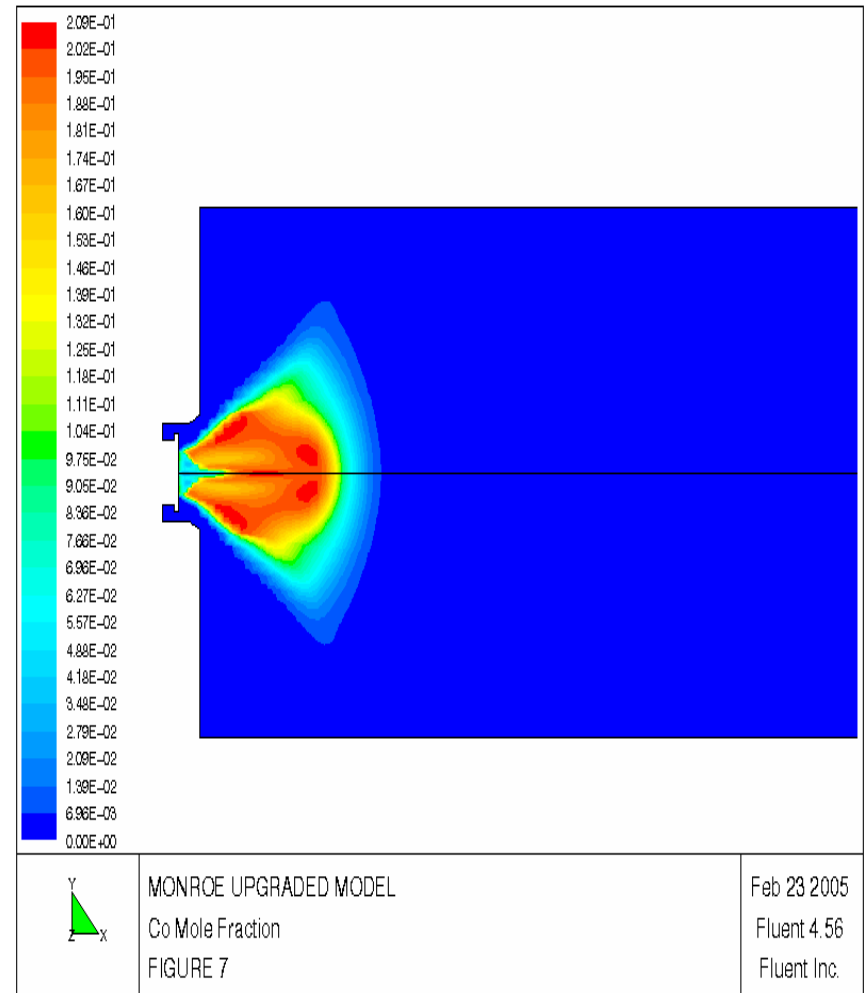

# Burner Modeling – the Overview

- **New burner configuration: conceptual model of flows**
- **Swirled air does increase flame turbulence, shortens flames and reduces tube wastage**
- **Good zone of recirculation in center of flame**
- **Good control of stoichiometry for NO<sub>x</sub> management**

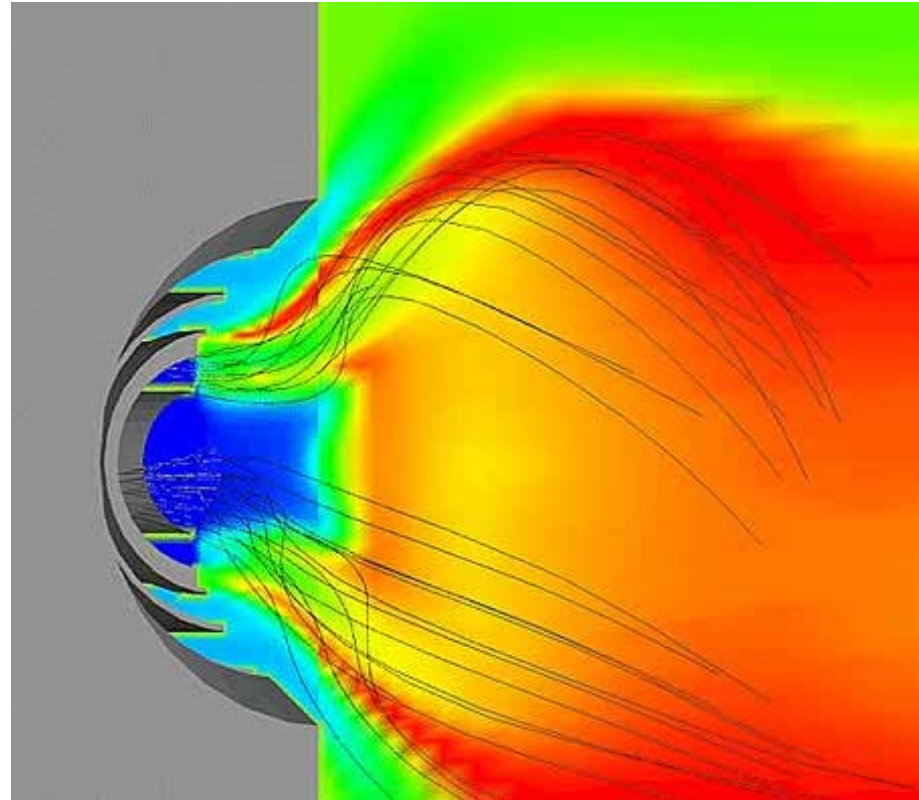

# Picture of the Flame From Modified Burners

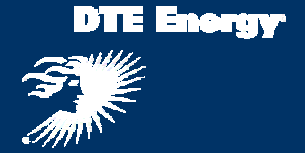

# Picture of the Flame from the Modified Burners

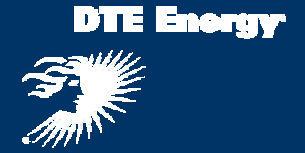



# Technology #3: Instrumentation for CO/LOI/FEGT

- **Installed GE/MK Probes to quantify CO emissions leaving the boiler along with LOI and FEGT**
  - LOI and FEGT are 0 – 1 scale signals
  - LOI and FEGT signal need interpretation
- **DTE Energy Personnel Developed Scales for LOI and FEGT**
  - Permit conversion to conventional units
  - Permit LOI and FEGT mapping across boiler
- **LOI Really an Indication of Char Particles Leaving the Primary Furnace**
  - Has been a real issue at Monroe Power Plant



# Installation Details

- **Installed probes as shown**
- **Developed computer screens for shift supervisors, supervising operators**
- **Developed computer screens for engineers**
- **Used the data to document when problems occur – maximize benefits of fuel blending and modified burners**





# GE/MK Probe Electronics





# Data Screen for Operators on DCS

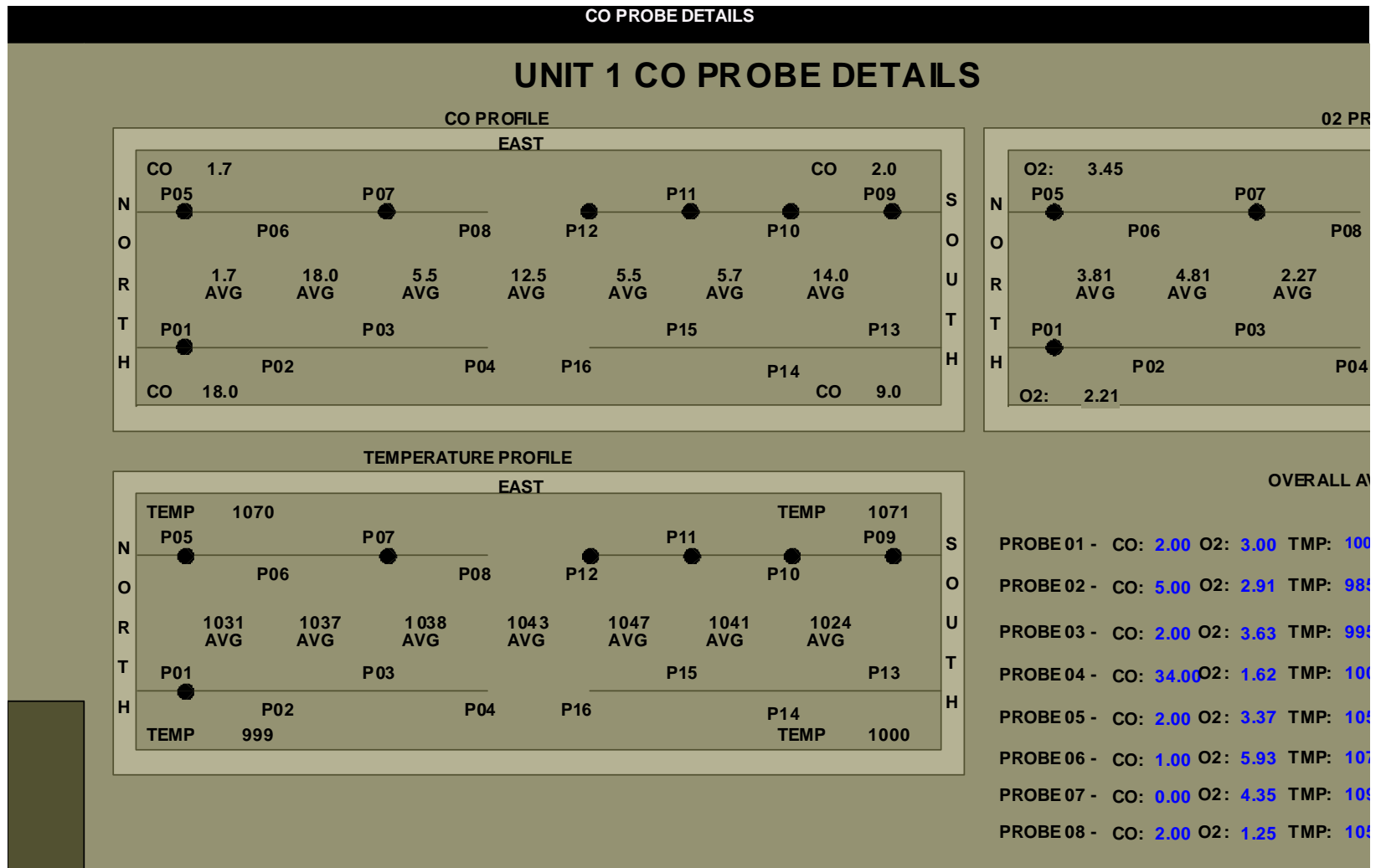



# Computer Screen #1 for Shift Supervisors and SO's

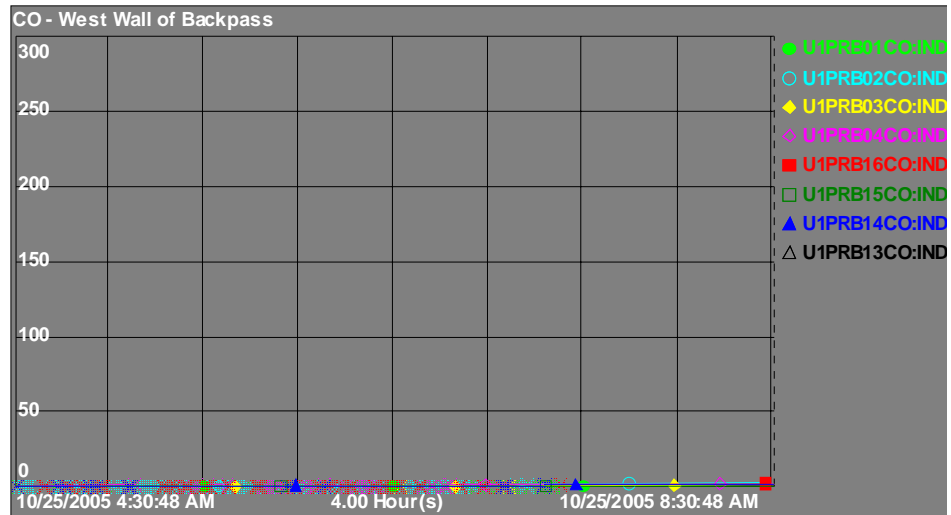
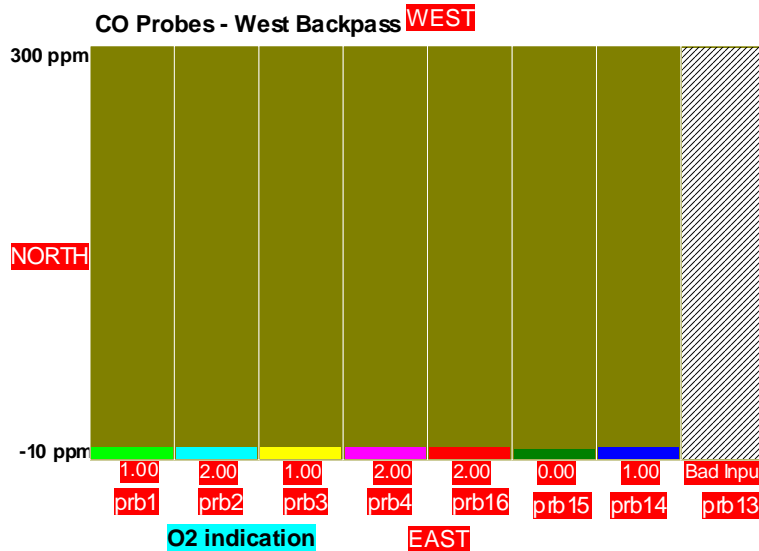
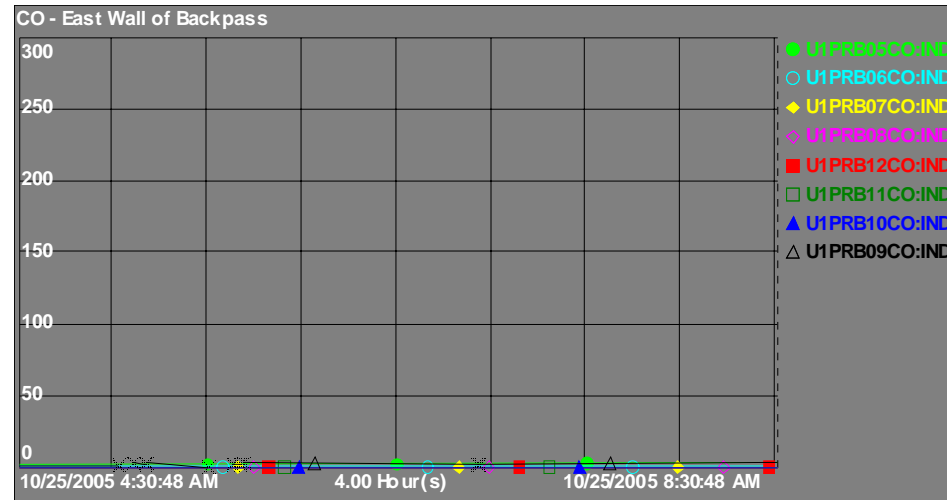
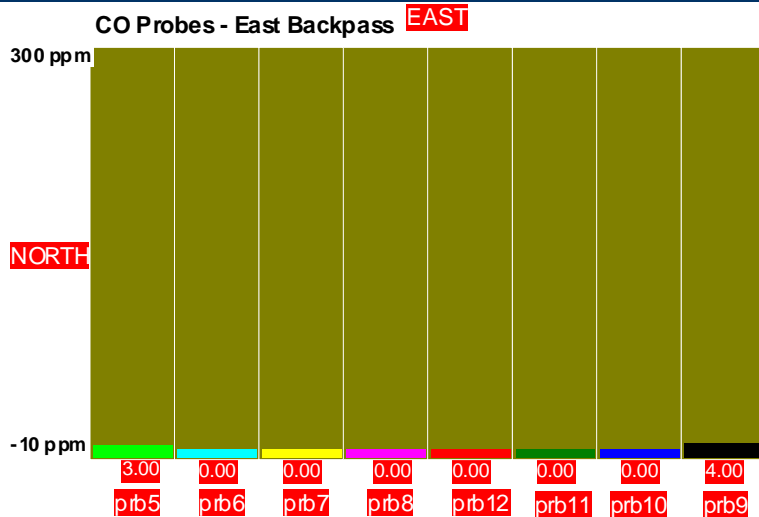

# Computer Screen #2 for Shift Supervisors and SO's

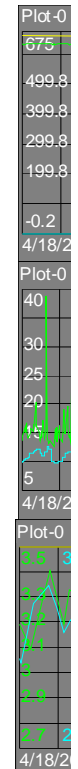
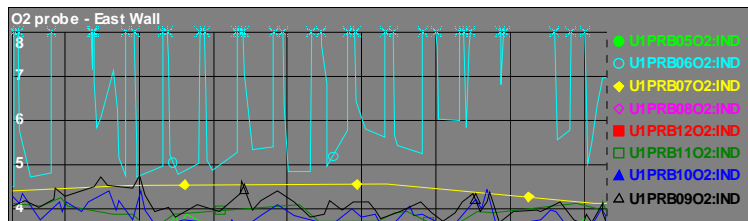
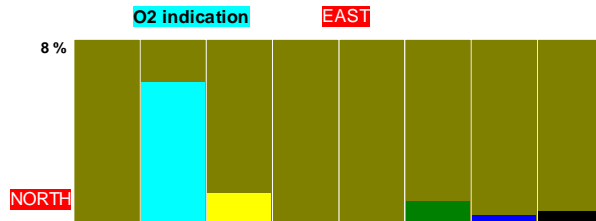
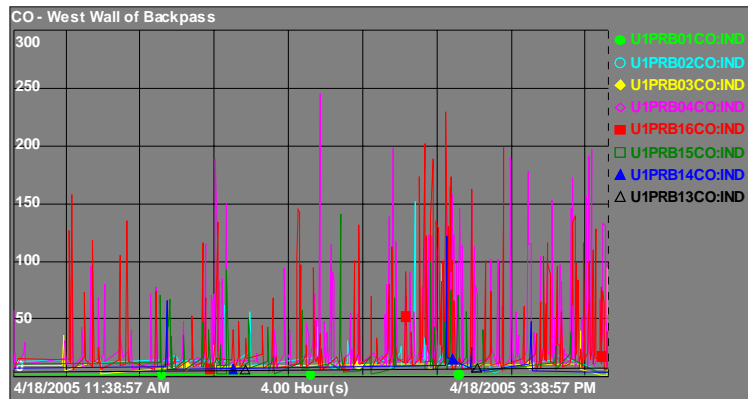
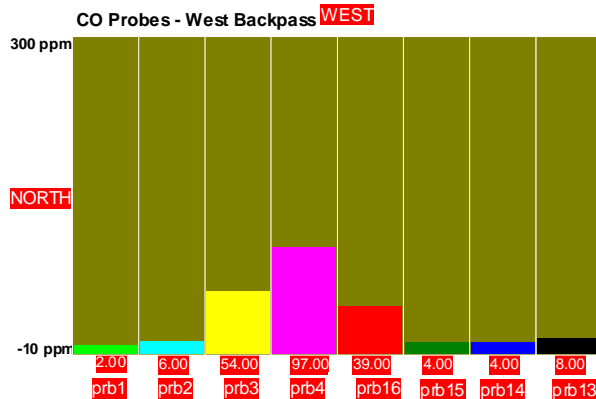
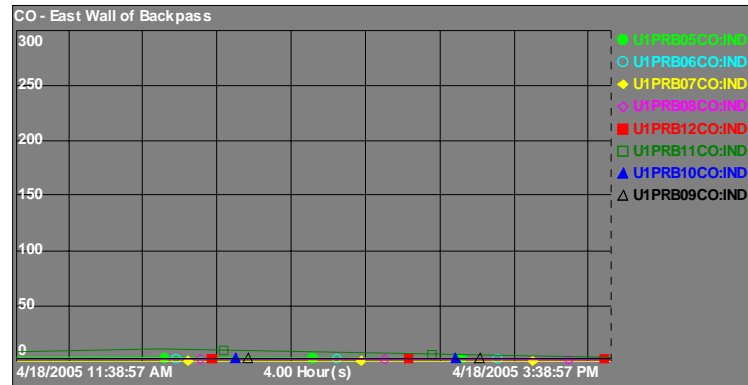
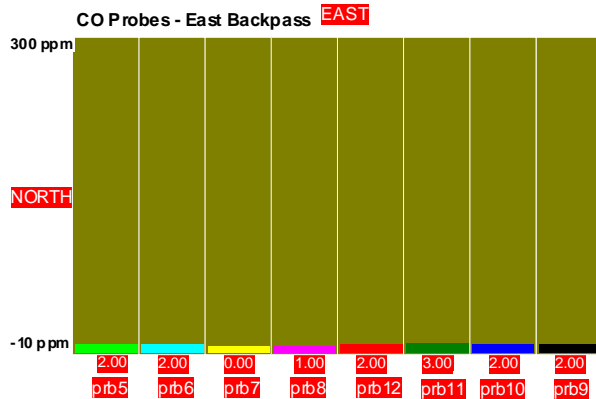
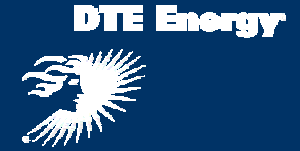

# Computer Screen #3 for Shift Supervisors and SO's

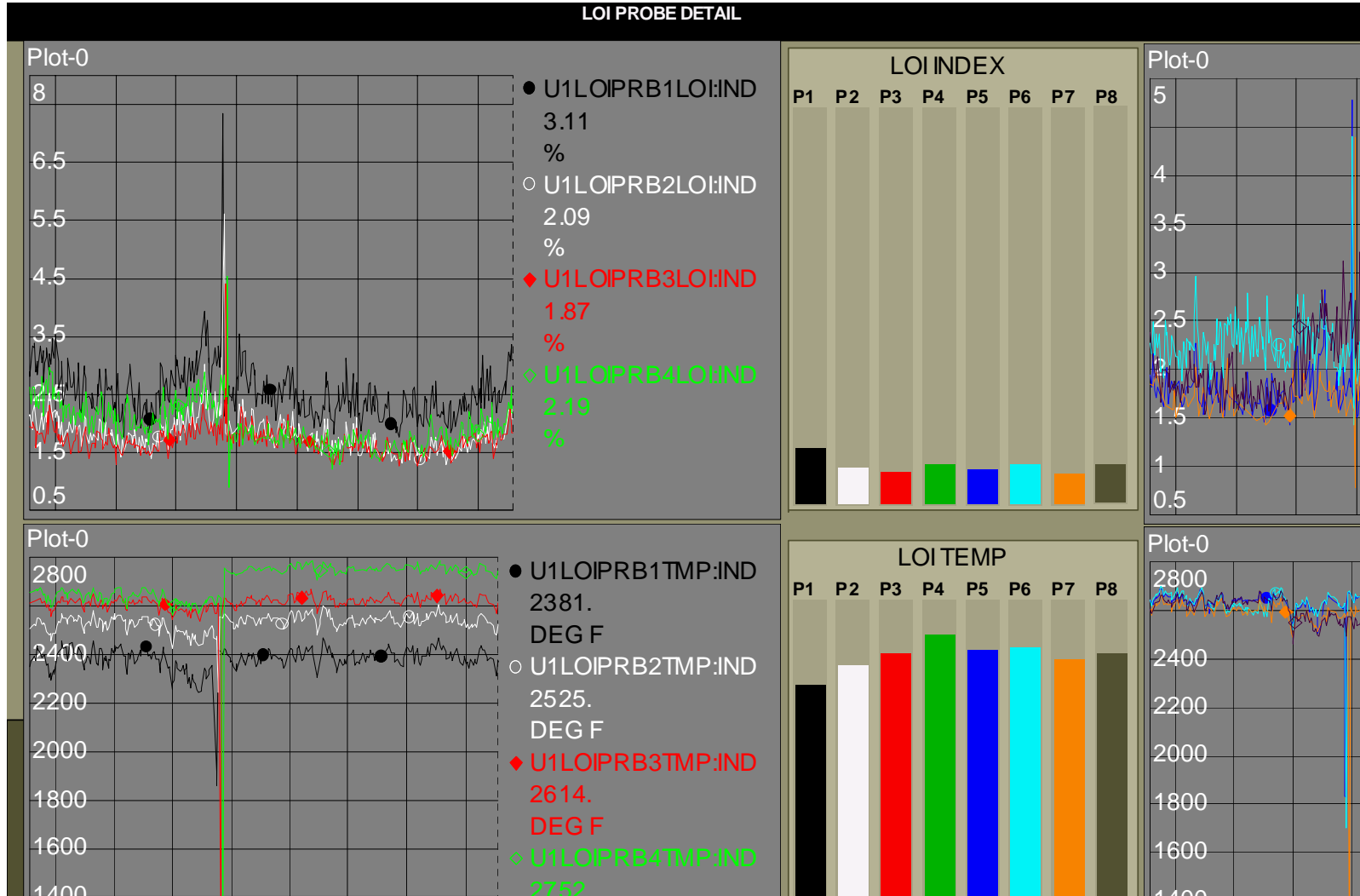
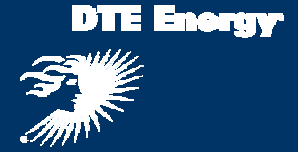



# Computer Screen #4 for Shift Supervisors and SO's - LOI

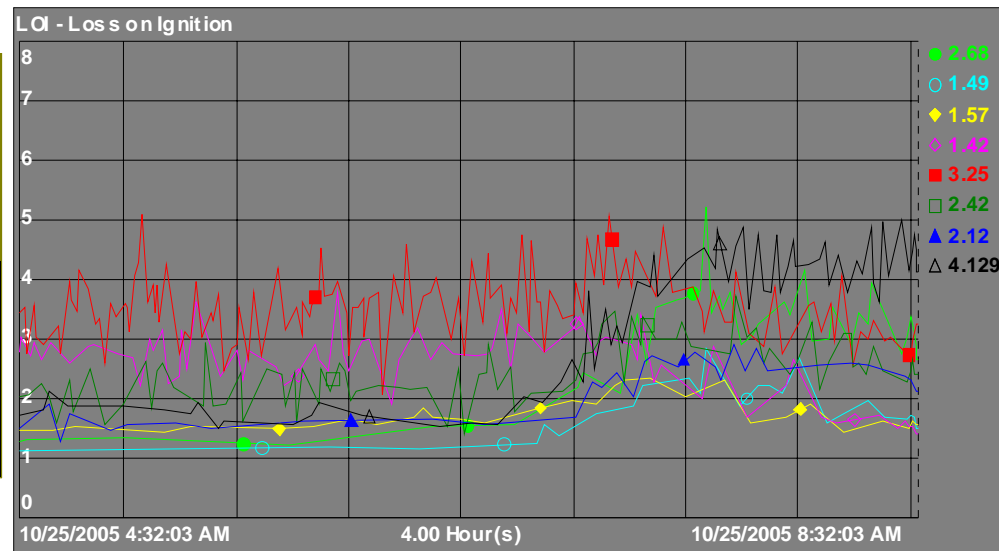
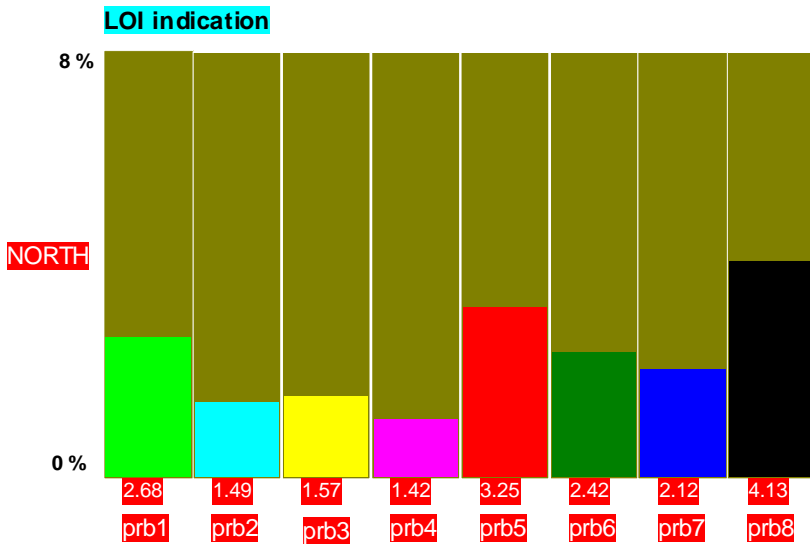

# Computer Screen #5 for Shift Supervisors and SO's - FEGT

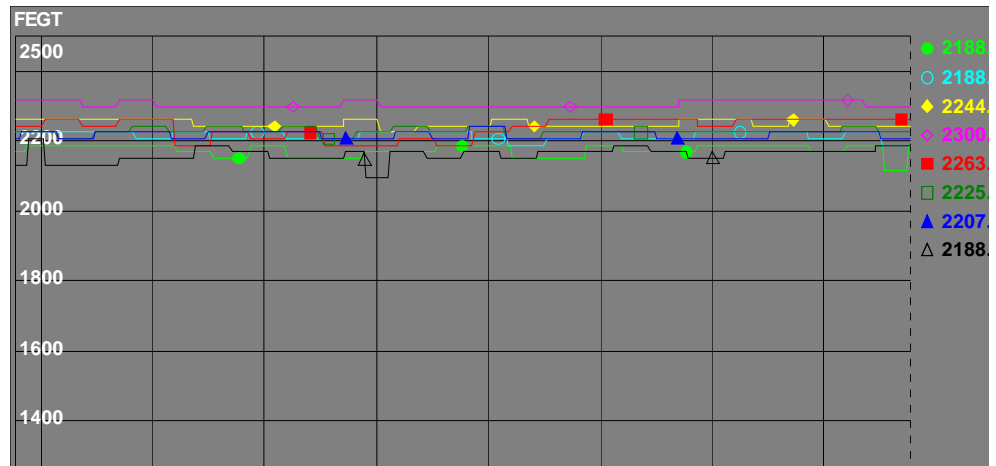
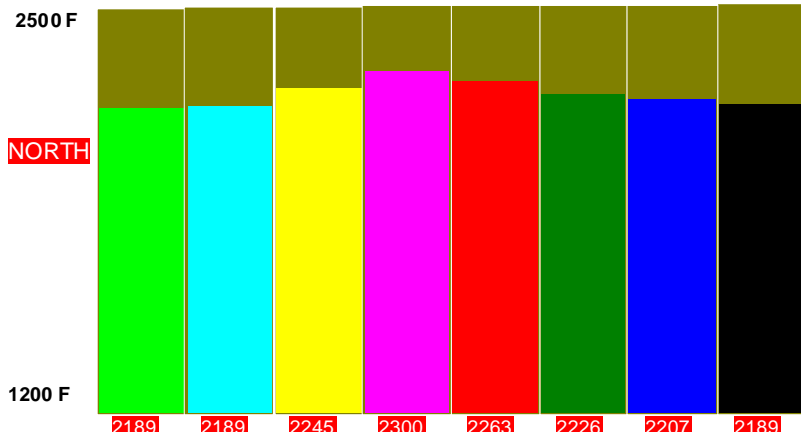
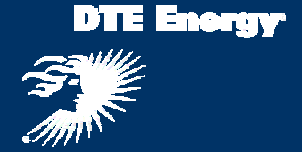



# Shift Sup's and SO's are Trained in How to Respond to Issues

- **Fuel Issues for Response**
  - Low volatility
  - High moisture
  - High ash
  - Base/Acid Ratio
- **GE/MK Probe Indicators (in combination with fuels)**
  - Lanes with High CO or LOI (burner problem)
  - Lanes with High FEGT (potential start of slagging issue)
  - Overall low CO (too low indicates potential for higher than desired NO<sub>x</sub>)
  - Overall high CO or LOI (potential for combustion problems)



# Other Technologies Implemented with XRF, Burners, Probes

- **Dense Pack on Turbine for Improved Net Station Heat Rate**
- **SIRS and Rapper Improvements on Electrostatic Precipitators to Overcome Limitations of Small ESP's**
  - Increase capability for higher mass gas flows to ESP
  - Capability for burning higher percentage PRB coal blends without capacity limitations from ESP's (higher percentage PRB increases volatility, decreases NO<sub>x</sub>)
- **Precipitators**
  - Went from 20 traditional TR sets to 48 SIRS
  - Went from 160 rappers to 320 rappers
  - Power level in precipitator went from 1200 kW to 2200 kW

# Precipitator Improvements: Rappers and SIRS



# Monroe Unit #2 Improvements Attributable to Combustion Program and New Burners



- **Reduced NO<sub>x</sub> Emissions from 0.55 lb/10<sup>6</sup> Btu to <0.35 lb/10<sup>6</sup> Btu at Full Load**
- **Increased Full Load to 795 MW (ECAR test at 804 MW)**
- **50 - 100 Btu/kWh Reduction in Net Station Heat Rate from Burners and Instrumentation**
- **Support for the >75 MW Capacity Increase in combination with precipitator improvements and turbine dense pack**
- **Reduction in unburned carbon in ash**
- **Reduction in CO emissions (ppmv) by 25%**



# Results of Program on MPP #2

- **Increased Percentage of PRB [LSW] Coal in Blend from 58% to 62%**
  - Progress resulting from on-line analyzer
  - Progress resulting from combustion improvements
- **Only One Major Slagging Incident Occurred in 2005**
- **NO<sub>x</sub> Emissions Have Been Reduced**
  - Higher Percentage of PRB in Blend
  - Use of New Low NO<sub>x</sub> Burners in Unit 2
- **Many More Benefits to Monroe**





# Next Steps in Combustion Program

- **Continue NO<sub>x</sub> Reduction in context of overall combustion program**
- **Determine maximum capacity for coal blends with up to 75% PRB [low sulfur western] coal by testing**
- **Install intelligent sootblowing across plant**
- **Install burner mods across plant**
- **Upgrade mills to increase capacity and performance**

